

Signet 2552 Metal Magmeter Flow Sensors



The Signet 2552 Metal Magmeter from Georg Fischer features all-stainless steel construction. The PVDF nosepiece and FKM O-rings are the only other wetted materials. The 2552 installs quickly into standard 1¼ in. or 1½ in. pipe outlets, and is adjustable to fit pipes from DN50 to DN2550 (2 to 102 inches). Two sensor lengths allow maximum flexibility to accommodate a variety of hardware configurations, including ball valves for hot-tap installations.

When equipped with the frequency output, the 2552 is compatible with any externally powered Signet flow instrument, while the digital (S³L) output enables multi-channel compatibility with Signet 8900, 9900 or 9950 Multi-Parameter instruments. Select the blind 4 to 20 mA current output to interface directly with data loggers, PLCs or telemetry systems. Key features include Empty Pipe Detection, LED-assisted troubleshooting, and bi-directional span capability (in 4 to 20 mA models).

The Signet 3-0252 Configuration Tool is available to customize every performance feature in the 2552 so it can be adapted to the user's application requirements.

Features

- NIST test certificate included
- Award winning hot-tap magnetic flow sensor up to DN2550 (102 in.)
- Patented Magmeter technology*
- Operating range 0.05 to 10 m/s (0.15 to 33 ft/s)
- Reliable operation in harsh environments
- Repeatable: ±0.5% of reading @ 25 °C
- Three output options: 4 to 20 mA, Frequency/ Digital (S³L)
- ISO or NPT Threads



Applications

- Municipal Water Distribution
- Process and Coolant Flow
- Chemical Processing
- Wastewater
- Mining Applications
- Water Process Flow
- HVAC

* U.S. Patent No: 7,055,396 B1

Specifications

General			
Operating Range	Minimum	0.05 m/s	0.15 ft/s
	Maximum	pipes to DN1200 (48 in.) pipes over DN1200 (48 in.)	10 m/s 3 m/s
Pipe Size Range	DN50 to DN2550	2 in. to 102 in.	
Linearity	± 1% reading plus 0.1% of full scale		
Repeatability	±0.5% of reading @ 25 °C		
Accuracy	±2% of measured value*		
*In reference conditions where the fluid is water at ambient temperature, the sensor is inserted at the correct depth and there is a fully developed flow profile which is in compliance with ISO 7145-1982 (BS 1042 section 2.2)			
Minimum Conductivity	20 µs/cm		
Wetted Materials			
Body and Electrodes	316L stainless steel		
Insulator	PVDF		
O-rings	FKM		
Cable	4-cond + shield, PVC jacket (Fixed cable models) or Water-resistant rubber cable assembly with Turck® NEMA 6P connector		
Power Requirements			
4 to 20 mA	24 VDC ±10%, regulated, 22.1 mA maximum		
Frequency	5 to 24 VDC ±10%, regulated, 15 mA maximum		
Digital (S ³ L)	5 to 6.5 VDC 15 mA maximum		
Reverse Polarity and Short Circuit Protected			
Cable Options			
Fixed cable	7.6 m	25 ft	
Detachable water tight sensor cable with Turck® connector (sold separately) two lengths: 4 m (13 ft) or 6 m (19.5 ft)			
Electrical			
Current Output (4 to 20 mA)	Programmable and Reversible		
	Loop Accuracy	32 µA max. error (@ 25 °C @ 24 VDC)	
	Temperature Drift	±1 µA per °C max.	
	Power Supply Rejection	±1 µA per V	
	Isolation	Low voltage < 48 VAC/DC from electrodes and auxiliary power	
	Maximum Cable	300 m	1000 ft
	Max. Loop Resistance	300 Ω	
Frequency Output	Error Condition	22.1 mA	
	Compatible with	Signet 8900, 9900, 9900-1BC and 9950	
	Max. Pull-up Voltage	30 VDC	
	Short Circuit Protected	≤30 V @ 0 Ω pull-up for one hour	
	Reverse Polarity Protected	to -40 V for 1 hour	
	Overvoltage Protected to +40 V for 1 hour		
	Max. Current Sink	50 mA, current limited	
Digital (S ³ L) Output	Maximum Cable	300 m	1,000 ft
	Compatible with	Signet 8900, 9900, 9950 and 0486	
	Serial ASCII, TTL level 9600 bps		
Operating Temp.	Maximum Cable	Application dependent (See 8900 or 9900 manual) in non-icing conditions	
	Ambient (non-icing conditions)	-15 °C to 70 °C	5 °F to 158 °F
Max. Operating Pressure	Media	-15 °C to 85 °C	5 °F to 185 °F
	20.7 bar @ 25 °C	300 psi @ 77 °F	
Hot-Tap Installation Requirements			
Maximum Installation Pressure	20.7 bar		300 psi
Maximum Installation Temp (Insertion/Removal)	40 °C		104 °F
Do not use hot-tap installation where temperatures will exceed 40 °C or if hazardous liquids are present.			
Shipping Weights			
3-2552-2X-A-11/A-12	2.50 kg	5.51 lb	
3-2552-2X-B-11/B-12	2.30 kg	5.07 lb	
3-2552-3X-A-11/B-11/A-12/B-12	4.00 kg	8.81 lb	
Standards and Approvals			
CE, FCC			
RoHS compliant, China RoHS			
NEMA 4 (IP65)	Fixed cable models		
NEMA 6P (IP68)	Submersible cable models only. Signet recommends maximum 3 m (10 ft) submersion depth for maximum 10 days continuous submersion.		
Manufactured under ISO 9001 for Quality and ISO 14001 for Environmental Management and OHSAS 18001 for Occupational Health and Safety			

Dimensions

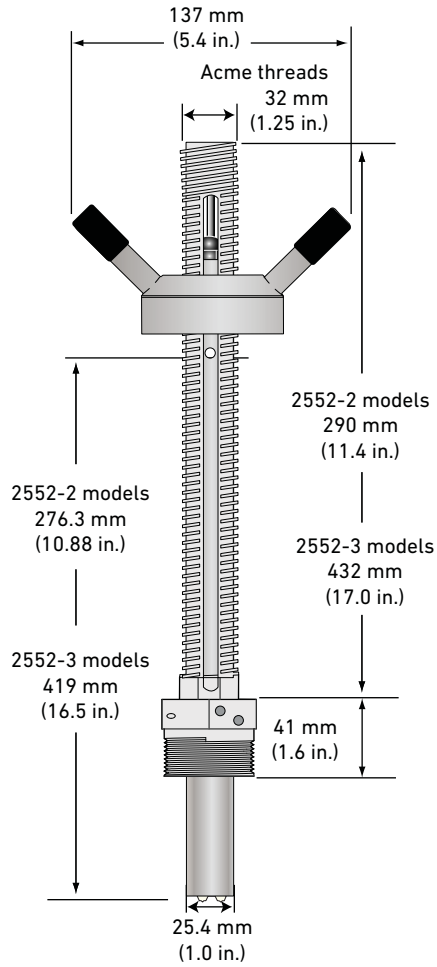

In-Line Installation

System Overview

Panel Mount	Pipe, Tank, Wall Mount	4 to 20 Output	Automation System				
Signet Instruments 8900 9900 9900-1BC 9950	Signet Instruments 9900 with 3-8050 Universal Mount Kit 9900-1P 9900-1BC with Rear Enclosure 9950	Customer Supplied Chart Recorder, Programmable Logic Controller, or Programmable Automation Controller	0486 Profibus Concentrator and Customer Supplied Programmable Logic Controller or Programmable Automation Controller				
Signet 2552 Magmeter (Standard or Hot-Tap) 							
ball or gate valve 1¼" or 1½"		nipple 1¼" or 1½"		Weld-on weldolet 1¼" or 1½" outlet		Iron strap-on saddle 1¼" or 1½" outlet	

All sold separately

Sensor Selection Guide

The 2552 Magmeter can be installed into a variety of pipe sizes. Follow the steps below to ensure that you choose the right sensor for your application.

Step 1: Determine how the sensor will be installed

A. For standard (non Hot-Tap) installations:

The height of the weldolet (threadolet) and pipe adapter(s) should be determined before the sensor is purchased.

- For retrofit installations, the stack height, or "A" dimension (see Fig. 1), is the overall height from the top of the pipe to the highest point of the stack.
- Sensor tip must be positioned at 10% of pipe ID
- For new installations, Signet recommends a weldolet (threadolet) and an adapter to accommodate the 1 ¼ in. (or 1 ½ in. for 2552-3) sensor process threads. The stack height, or "A" dimension (see Fig. 1), is the overall height from the top of the pipe to the highest point of the stack before the sensor is connected

B. For Hot-Tap installations:

The stack height of the ball valve, nipple weldolet (threadolet) and pipe adapters should be determined before the sensor is purchased.

- For retrofit installations, the ball valve must be at least a 1 ¼ in. (or 1 ½ in. for 2552-3) valve. The stack height, or "A" dimension (see Fig. 2), is the overall height from the top of the pipe to the top of the ball valve.
- Sensor tip base must be positioned at 10% of pipe ID
- For new installations, Signet recommends a 1 ¼ in. or 1 ½ in. full port ball valve, a short nipple and a weldolet (threadolet). The stack height or "A" dimension (see Fig. 2) is the overall height from the top of the pipe to the top of the ball valve before the sensor is connected.

Fig. 1
Standard installation with "A" dimension using a weldolet (threadolet)

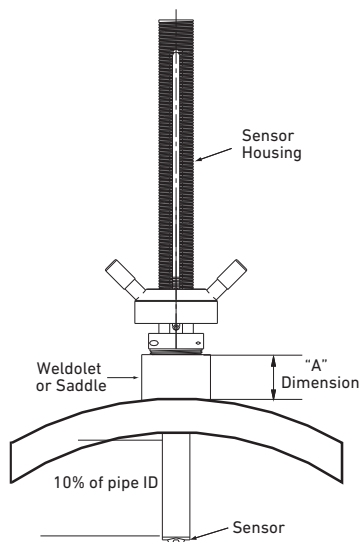
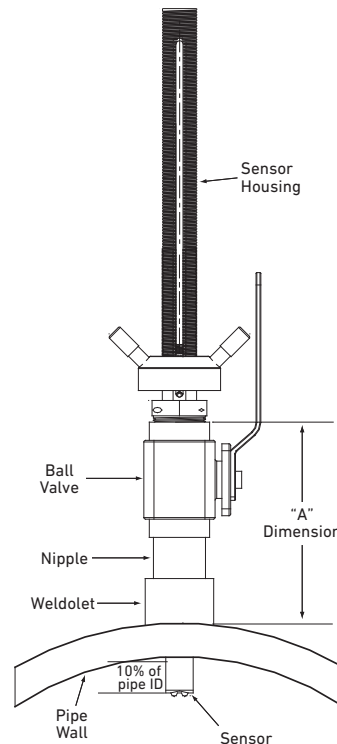

Fig. 2
Hot-Tap installation with "A" dimension using a ball valve, short nipple and weldolet (threadolet)



Step 2: Determine how the sensor will be installed

Once the "A" dimension is determined, go to the sensor selection table and find your "A" dimension on the left column. Next, find the appropriate pipe size at the top of the chart. To determine the correct sensor size locate where the pipe size column meets the max "A" dimension row.

		Pipe Size																											
		inches	2	2.5	3 to 3 1/2	4	5	6 to 8	10	12 to 14	16	18	20	22	24	26 to 28	30 to 32	34	36 to 38	40 to 42	48	54	60	66	72	78	84	102	
		DN	50	65	80 to 90	100	125	150 to 200	250	300 to 350	400	450	500	550	600	650 to 700	750 to 800	850	900 to 950	1000 to 1100	1200	1400	1500	1700	1800	2000	2100	2.58 m	
Max. "A" Dim	mm	inches	2	2	2	2	2	2	2	2	2	2	2	2	2	2	2	2	2	2	2	2	2	3	3	3	3	3	3
	50.8	2	2	2	2	2	2	2	2	2	2	2	2	2	2	2	2	2	2	2	2	2	2	3	3	3	3	3	3
	63.5	2.5	2	2	2	2	2	2	2	2	2	2	2	2	2	2	2	2	2	2	2	2	2	3	3	3	3	3	3
	76.2	3	2	2	2	2	2	2	2	2	2	2	2	2	2	2	2	2	2	2	2	2	2	3	3	3	3	3	3
	88.9	3.5	2	2	2	2	2	2	2	2	2	2	2	2	2	2	2	2	2	2	2	2	2	3	3	3	3	3	3
	101.6	4	2	2	2	2	2	2	2	2	2	2	2	2	2	2	2	2	2	2	2	2	2	3	3	3	3	3	3
	114.3	4.5	2	2	2	2	2	2	2	2	2	2	2	2	2	2	2	2	2	2	2	2	2	3	3	3	3	3	
	127	5	2	2	2	2	2	2	2	2	2	2	2	2	2	2	2	2	2	2	2	2	2	3	3	3	3	3	
	139.7	5.5	2	2	2	2	2	2	2	2	2	2	2	2	2	2	2	2	2	2	2	2	2	3	3	3	3	3	
	152.4	6	2	2	2	2	2	2	2	2	2	2	2	2	2	2	3	3	2	3	3	3	3	3	3	3	3	3	
	165.1	6.5	2	2	2	2	2	2	2	2	2	2	3	3	3	3	3	3	3	3	3	3	3	3	3	3	3	3	
	177.8	7	2	2	2	2	2	2	2	2	2	3	3	3	3	3	3	3	3	3	3	3	3	3	3	3	3		
	190.5	7.5	2	2	2	2	2	2	2	2	3	3	3	3	3	3	3	3	3	3	3	3	3	3	3	3			
	228.6	9	2	3	3	3	3	3	3	3	3	3	3	3	3	3	3	3	3	3	3	3	3	3					
	241.3	9.5	3	3	3	3	3	3	3	3	3	3	3	3	3	3	3	3	3	3	3	3	3	3					
	254	10	3	3	3	3	3	3	3	3	3	3	3	3	3	3	3	3	3	3	3								
	266.7	10.5	3	3	3	3	3	3	3	3	3	3	3	3	3	3	3	3	3	3									
	279.4	11	3	3	3	3	3	3	3	3	3	3	3	3			3	3	3										
	292.1	11.5	3	3	3	3	3	3	3	3	3	3	3	3			3												
	304.8	12	3	3	3	3	3	3	3	3	3	3	3																
317.5	12.5	3	3	3	3	3	3	3	3																				
330.2	13	3	3	3	3	3	3	3																					
342.9	13.5	3	3	3	3	3	3																						
355.6	14	3	3	3	3	3																							
375.9	14.8	3	3																										
381	15																												

Legend:

- 2: Use 3-2552-2, max. insertion = 236 mm (9.3 in.)
- 3: Use 3-2552-3, max. insertion = 368 mm (14.8 in.)

This chart is based on the thickest commonly available pipe.

Step 3: Refer to Ordering Information to select corresponding part numbers

Ordering Notes

- 1) Sensor insertion depth is the distance from the bottom of the sensor housing to the tip of the sensor.
- 2) Hot-Tap installations require a 1 1/4 in. or 1 1/2 in. ball valve.
- 3) See Sensor Selection Guide on previous page to determine the sensor length required.

Application Tips

- Minimum process liquid conductivity requirement is 20 µS/cm.
- 1 1/2 x 1 1/4 inch and 2 x 1 1/4 inch (2552-2 only) retrofit adapters are available for replacement installations of Signet 2552 and 2540 sensors.

Ordering Information

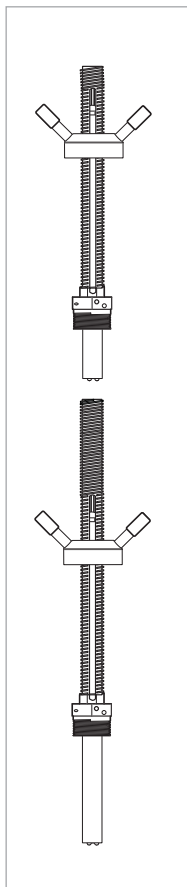

Mfr. Part No.	Code	Sensor Insertion Depth	Process Connection Thread Options
Frequency or Digital (S³L) output			
for use with any Signet Flow or Multi-Parameter Instruments			
Fixed cable, 7.6 m (25 ft); no connector			
3-2552-21-A-11	159 001 513	9.3 inches*	1 ¼ inch NPT**
3-2552-22-A-11	159 001 517	9.3 inches*	1 ¼ inch ISO**
3-2552-33-A-11	159 001 521	14.8 inches*	1 ½ inch NPT**
3-2552-34-A-11	159 001 522	14.8 inches*	1 ½ inch ISO**
Watertight sensor connector; cable sold separately			
3-2552-21-B-11	159 001 515	9.3 inches*	1 ¼ inch NPT**
3-2552-22-B-11	159 001 519	9.3 inches*	1 ¼ inch ISO**
3-2552-33-B-11	159 001 523	14.8 inches*	1 ½ inch NPT**
3-2552-34-B-11	159 001 524	14.8 inches*	1 ½ inch ISO**
4 to 20 mA output			
Fixed cable, 7.6 m (25 ft); no connector			
3-2552-21-A-12	159 001 514	9.3 inches*	1 ¼ inch NPT**
3-2552-22-A-12	159 001 518	9.3 inches*	1 ¼ inch ISO**
3-2552-33-A-12	159 001 525	14.8 inches*	1 ½ inch NPT**
3-2552-34-A-12	159 001 526	14.8 inches*	1 ½ inch ISO**
Watertight sensor connector; cable sold separately			
3-2552-21-B-12	159 001 516	9.3 inches*	1 ¼ inch NPT**
3-2552-22-B-12	159 001 520	9.3 inches*	1 ¼ inch ISO**
3-2552-33-B-12	159 001 527	14.8 inches*	1 ½ inch NPT**
3-2552-34-B-12	159 001 528	14.8 inches*	1 ½ inch ISO**

* Customer must determine stack height (ball valve, nipple, weldolet, etc.). Refer to Sensor Selection on previous page to determine "A" dimension. Sensor tip must be positioned at 10% of pipe ID.

** 1 ¼ inch process connection is the standard thread size on the 3-2552-2X-X-XX: For the 2552-3 the 1 ½ inch process connection is standard and the 1 ¼ inch is available as a special order.

Accessories and Replacement Parts

Mfr. Part No.	Code	Description
2120-1512	159 001 425	1 ½ x 1 ¼ inch NPT adapter for retrofitting 2540 installation to 2552 - 316 SS
2120-2012	159 001 426	2 x 1 ¼ inch NPT adapter for retrofitting 2550 installation to 2552 - 316 SS
3-2552.392	159 001 530	1 ¼ inch NPT full port stainless steel ball valve and nipple kit
3-2552.393	159 001 531	1 ¼ inch NPT full port brass ball valve & nipple kit
3-2552.394	159 001 532	1 ½ inch NPT conduit adapter, aluminum for -1 and -2 units
4301-2125	159 001 533	1 ¼ inch NPT full port ball valve - brass
4301-3125	159 001 387	1 ¼ inch NPT full port ball valve - stainless steel
5541-4184	159 001 388	4-conductor cable assembly with water-tight connector, 4 m (13 ft)
5541-4186	159 001 389	4-conductor cable assembly with water-tight connector, 6 m (19.5 ft)
special order	special order	4-conductor cable assembly with water-tight connector, cable length in 25 ft increments
special order	special order	1 ¼ in. NPT or ISO process connection threads to replace 1 ½ in. NPT or ISO threads
3-0252	159 001 808	Configuration Tool

3-2552.099 Rev G (06/18)